

NO.	REVISION	BY	DATE
1	ISSUED FOR REVIEW	F.S.C.	10.19.20
2	REVISED PER THE COMMENTS	F.S.C.	04.20.21
3	REVISED PER THE COMMENTS	F.S.C.	04.20.21
4	REVISED PER THE COMMENTS DATED 04.17.21	F.S.C.	07.08.21
5	REVISED PER THE COMMENTS DATED 08.17.21	F.S.C.	08.17.21

Design of:
ADVANCE ENGINEERING & SURVEYING, PLLC
 CIVIL & ENVIRONMENTAL ENGINEERING
 LAND SURVEYING & DEVELOPMENT
 COMMERCIAL AND RESIDENTIAL

11 HERBERT DRIVE, LATHAM, N.Y. 12110
 PHONE: (518) 698-3772
 E-MAIL: ncospe@advanceeng.com

It is a condition of the Contract that the Engineer shall be held responsible for the accuracy of the information furnished to him by the client and for the accuracy of the information furnished to him by the client and for the accuracy of the information furnished to him by the client.

NICHOLAS COSTA, P.E.

DATE: NOVEMBER 20, 2019
 COUNTY OF ALBANY
 VILLAGE OF COLONIE
 STREET NO. 29 VLY ROAD
 PROPOSED SUBDIVISION
 CONSTRUCTION DETAILS-1

SCALE: NONE

DATE: NOVEMBER 20, 2019

OWNER:
 COLONIE CHRISTIAN
 LIFE CENTER, INC.
 P.O. BOX 12273
 ALBANY NY 12212
 APPLICANT:
 ROSETTI ACQUISITIONS
 427 NEW KARNER RD
 ALBANY, NY 12205

VILLAGE OF COLONIE PLANNING COMMISSION

SHEET NO.
DET-1
 14 OF 16 18187-S1E7

Figure 5A.17
 Grass Outlet Sediment Trap: ST-II

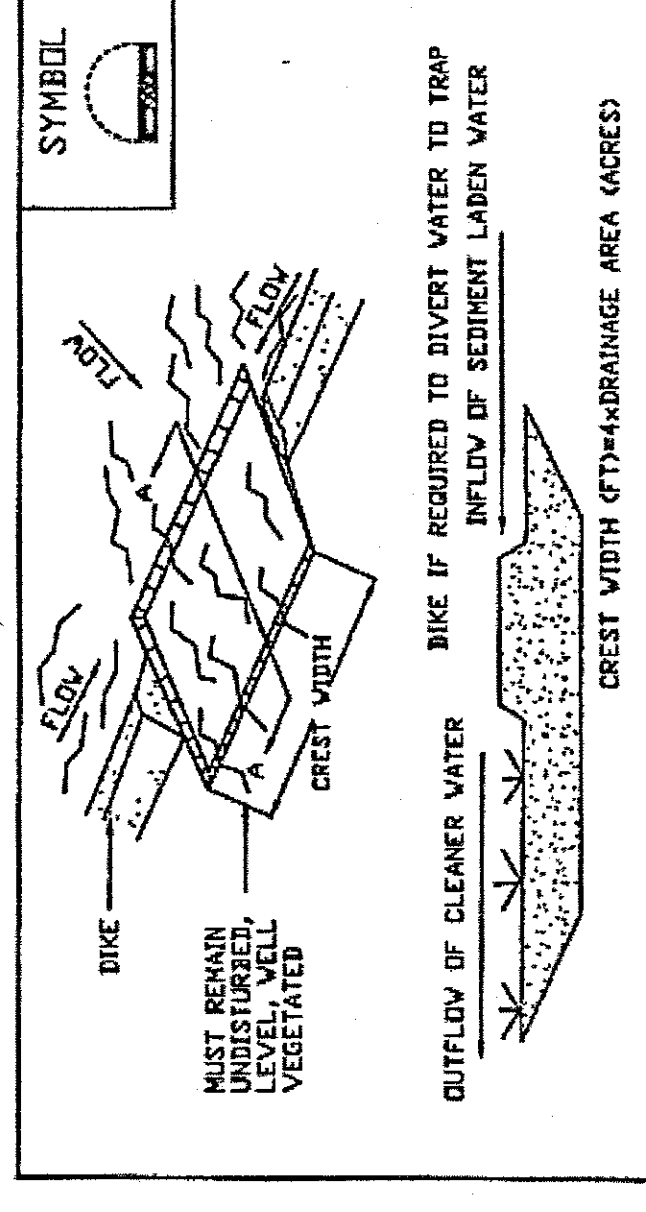

CONSTRUCTION SPECIFICATIONS

- VOLUME OF SEDIMENT STORAGE SHALL BE 3600 CUBIC FEET PER ACRE OF CONTIGUOUS DRAINAGE AREA.
- MINIMUM CREST WIDTH SHALL BE 4 X DRAINAGE AREA.
- SEDIMENT SHALL BE REMOVED AND TRAP RESTORED TO ITS ORIGINAL DIMENSIONS WHEN THE SEDIMENT HAS ACCUMULATED TO 1/2 THE DESIGN CAPACITY. THE TRAP SHALL BE MAINTAINED IN A SUITABLE AREA AND STABILIZED.
- THE STRUCTURE SHALL BE INSPECTED AFTER EACH RAIN AND REPAIRS MADE AS NEEDED.
- CONSTRUCTION OPERATIONS SHALL BE CARRIED OUT IN SUCH A MANNER THAT EROSION AND SEDIMENT ARE CONTROLLED.
- THE SEDIMENT TRAP SHALL BE REMOVED AND AREA STABILIZED WHEN THE REMAINING DRAINAGE AREA HAS BEEN PROPERLY STABILIZED.
- ALL CUT SLOPES SHALL BE 1:1 OR FLATTER.

MAXIMUM DRAINAGE AREA: 5 ACRES

ADAPTED FROM DETAILS PROVIDED BY USDA - NRCS, NEW YORK STATE DEPARTMENT OF ENVIRONMENTAL CONSERVATION, NEW YORK STATE SOIL & WATER CONSERVATION COMMITTEE

GRASS OUTLET SEDIMENT TRAP ST-II

August 2009
 Page 5A.40
 New York Standards and Specifications
 For Trenches and Sediment Control

August 2009
 Page 5A.40
 New York Standards and Specifications
 For Trenches and Sediment Control

STOP BAR PAVEMENT MARKING DETAIL

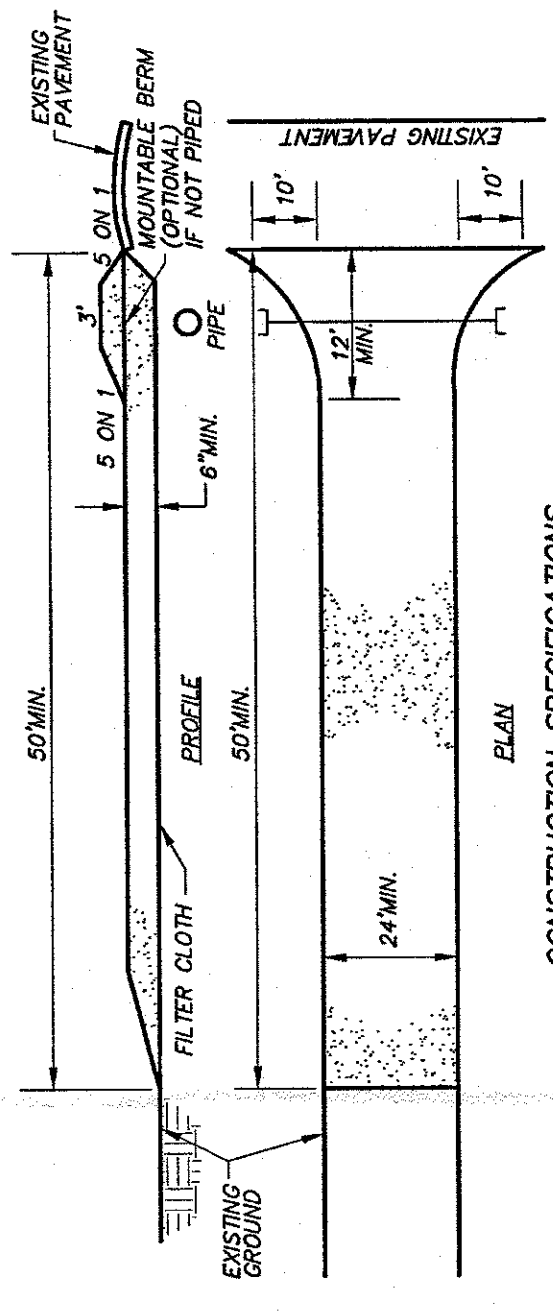

- CONSTRUCTION SPECIFICATIONS**
- STONE SIZE - USE 2" STONE, OR RECLAIMED OR RECYCLED CONCRETE EQUIVALENT.
 - LENGTH - AS REQUIRED, BUT NOT LESS THAN 30 FEET.
 - THICKNESS - NOT LESS THAN SIX (6) INCHES.
 - CONSTRUCTION SHALL BE IN ACCORDANCE WITH NYSDOT STANDARD SPECIFICATIONS SECTION 240 AND 241.
 - FLYER CLOTH - SHALL BE PLACED OVER THE ENTIRE AREA PRIOR TO PLACING OF STONE.
 - SURFACE WATER SHALL BE KEPT FROM THE STOP BAR. SURFACE WATER SHALL BE KEPT FROM THE STOP BAR. SURFACE WATER SHALL BE KEPT FROM THE STOP BAR.
 - WHEELS SHALL BE CLEANED WHEN NECESSARY TO REMOVE SEDIMENT FROM THE STOP BAR. WHEELS SHALL BE CLEANED WHEN NECESSARY TO REMOVE SEDIMENT FROM THE STOP BAR.
 - PERIODIC INSPECTION AND NEEDED MAINTENANCE SHALL BE PROVIDED AFTER EACH RAIN.

STABILIZED CONSTRUCTION ENTRANCE

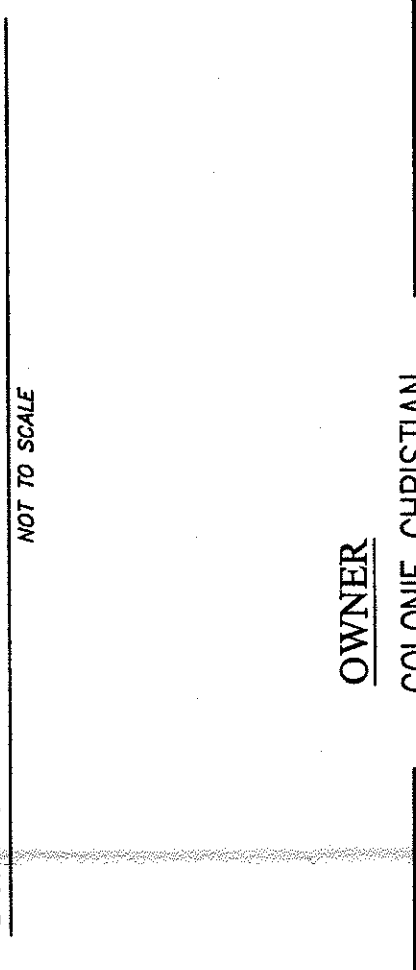

- CONSTRUCTION SPECIFICATIONS**
- STONE SIZE - USE 2" STONE, OR RECLAIMED OR RECYCLED CONCRETE EQUIVALENT.
 - LENGTH - AS REQUIRED, BUT NOT LESS THAN 30 FEET.
 - THICKNESS - NOT LESS THAN SIX (6) INCHES.
 - CONSTRUCTION SHALL BE IN ACCORDANCE WITH NYSDOT STANDARD SPECIFICATIONS SECTION 240 AND 241.
 - FLYER CLOTH - SHALL BE PLACED OVER THE ENTIRE AREA PRIOR TO PLACING OF STONE.
 - SURFACE WATER SHALL BE KEPT FROM THE STOP BAR. SURFACE WATER SHALL BE KEPT FROM THE STOP BAR. SURFACE WATER SHALL BE KEPT FROM THE STOP BAR.
 - WHEELS SHALL BE CLEANED WHEN NECESSARY TO REMOVE SEDIMENT FROM THE STOP BAR. WHEELS SHALL BE CLEANED WHEN NECESSARY TO REMOVE SEDIMENT FROM THE STOP BAR.
 - PERIODIC INSPECTION AND NEEDED MAINTENANCE SHALL BE PROVIDED AFTER EACH RAIN.

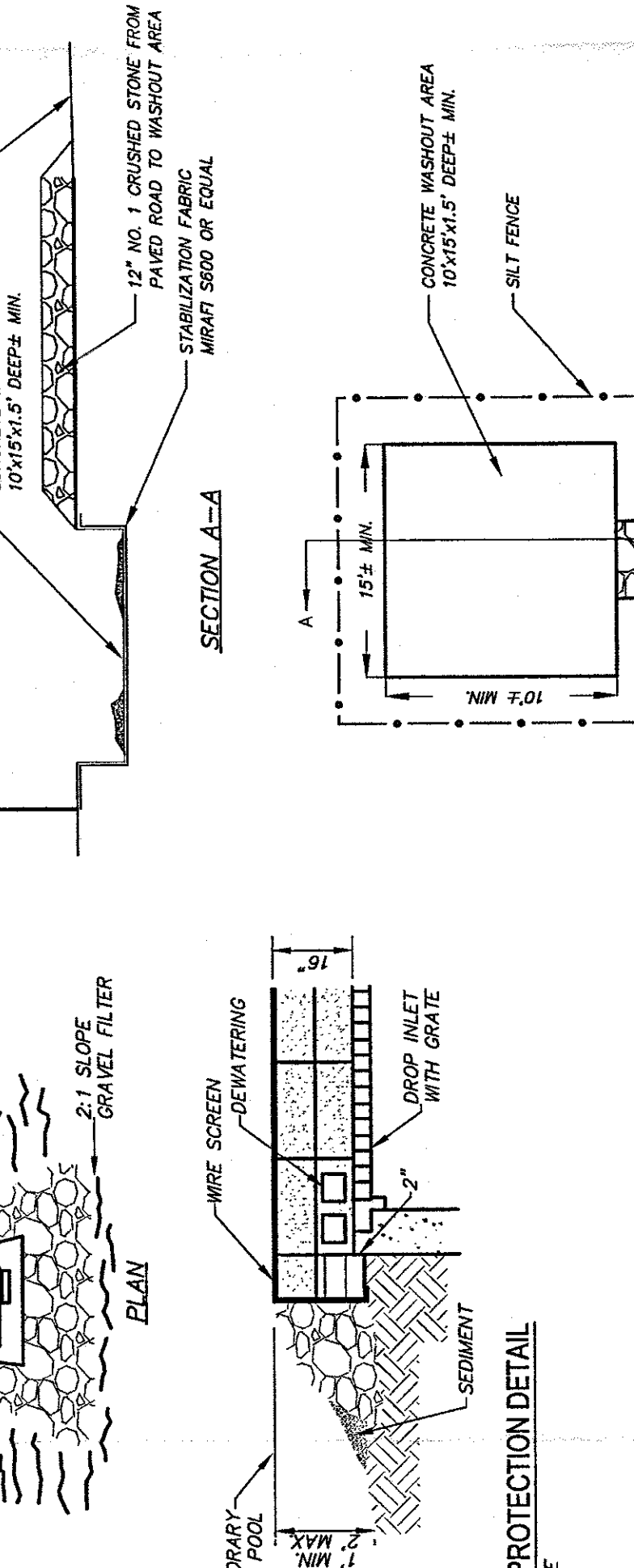

CONCRETE WASHOUT AREA

NOT TO SCALE

1. VOLUME OF SEDIMENT STORAGE SHALL BE 3600 CUBIC FEET PER ACRE OF CONTIGUOUS DRAINAGE AREA.
- MINIMUM CREST WIDTH SHALL BE 4 X DRAINAGE AREA.
- SEDIMENT SHALL BE REMOVED AND TRAP RESTORED TO ITS ORIGINAL DIMENSIONS WHEN THE SEDIMENT HAS ACCUMULATED TO 1/2 THE DESIGN CAPACITY. THE TRAP SHALL BE MAINTAINED IN A SUITABLE AREA AND STABILIZED.
- THE STRUCTURE SHALL BE INSPECTED AFTER EACH RAIN AND REPAIRS MADE AS NEEDED.
- CONSTRUCTION OPERATIONS SHALL BE CARRIED OUT IN SUCH A MANNER THAT EROSION AND SEDIMENT ARE CONTROLLED.
- THE SEDIMENT TRAP SHALL BE REMOVED AND AREA STABILIZED WHEN THE REMAINING DRAINAGE AREA HAS BEEN PROPERLY STABILIZED.
- ALL CUT SLOPES SHALL BE 1:1 OR FLATTER.

MAXIMUM DRAINAGE AREA: 5 ACRES

ADAPTED FROM DETAILS PROVIDED BY USDA - NRCS, NEW YORK STATE DEPARTMENT OF ENVIRONMENTAL CONSERVATION, NEW YORK STATE SOIL & WATER CONSERVATION COMMITTEE

CONCRETE WASHOUT AREA

August 2009
 Page 5A.40
 New York Standards and Specifications
 For Trenches and Sediment Control

August 2009
 Page 5A.40
 New York Standards and Specifications
 For Trenches and Sediment Control

STOP BAR PAVEMENT MARKING DETAIL

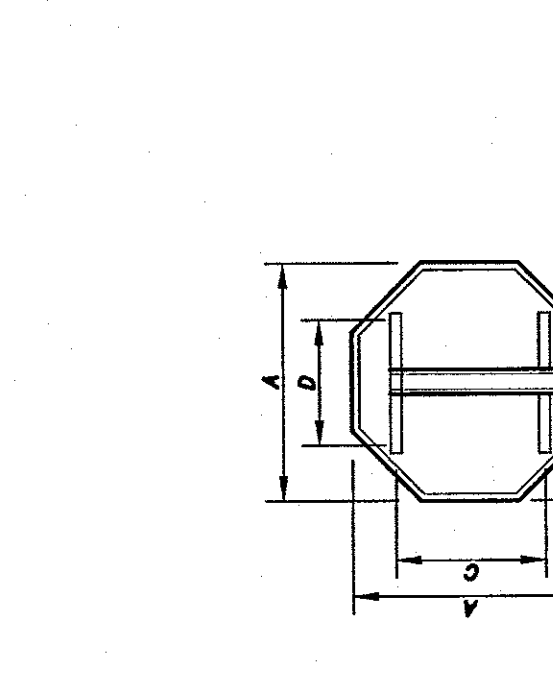

- CONSTRUCTION SPECIFICATIONS**
- STONE SIZE - USE 2" STONE, OR RECLAIMED OR RECYCLED CONCRETE EQUIVALENT.
 - LENGTH - AS REQUIRED, BUT NOT LESS THAN 30 FEET.
 - THICKNESS - NOT LESS THAN SIX (6) INCHES.
 - CONSTRUCTION SHALL BE IN ACCORDANCE WITH NYSDOT STANDARD SPECIFICATIONS SECTION 240 AND 241.
 - FLYER CLOTH - SHALL BE PLACED OVER THE ENTIRE AREA PRIOR TO PLACING OF STONE.
 - SURFACE WATER SHALL BE KEPT FROM THE STOP BAR. SURFACE WATER SHALL BE KEPT FROM THE STOP BAR. SURFACE WATER SHALL BE KEPT FROM THE STOP BAR.
 - WHEELS SHALL BE CLEANED WHEN NECESSARY TO REMOVE SEDIMENT FROM THE STOP BAR. WHEELS SHALL BE CLEANED WHEN NECESSARY TO REMOVE SEDIMENT FROM THE STOP BAR.
 - PERIODIC INSPECTION AND NEEDED MAINTENANCE SHALL BE PROVIDED AFTER EACH RAIN.

STABILIZED CONSTRUCTION ENTRANCE

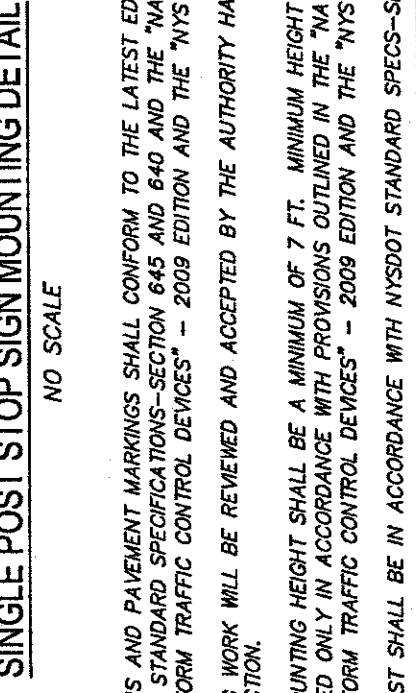

- CONSTRUCTION SPECIFICATIONS**
- STONE SIZE - USE 2" STONE, OR RECLAIMED OR RECYCLED CONCRETE EQUIVALENT.
 - LENGTH - AS REQUIRED, BUT NOT LESS THAN 30 FEET.
 - THICKNESS - NOT LESS THAN SIX (6) INCHES.
 - CONSTRUCTION SHALL BE IN ACCORDANCE WITH NYSDOT STANDARD SPECIFICATIONS SECTION 240 AND 241.
 - FLYER CLOTH - SHALL BE PLACED OVER THE ENTIRE AREA PRIOR TO PLACING OF STONE.
 - SURFACE WATER SHALL BE KEPT FROM THE STOP BAR. SURFACE WATER SHALL BE KEPT FROM THE STOP BAR. SURFACE WATER SHALL BE KEPT FROM THE STOP BAR.
 - WHEELS SHALL BE CLEANED WHEN NECESSARY TO REMOVE SEDIMENT FROM THE STOP BAR. WHEELS SHALL BE CLEANED WHEN NECESSARY TO REMOVE SEDIMENT FROM THE STOP BAR.
 - PERIODIC INSPECTION AND NEEDED MAINTENANCE SHALL BE PROVIDED AFTER EACH RAIN.

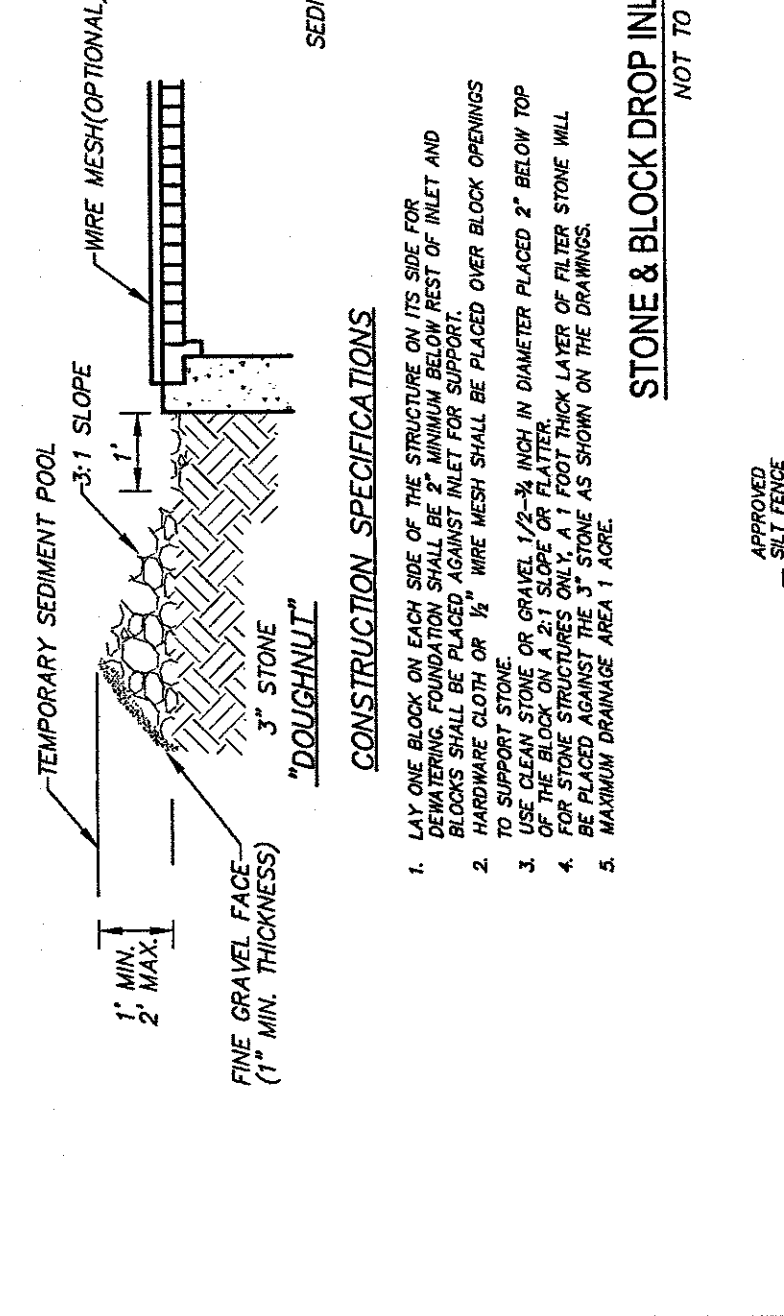

STONE & BLOCK DROP INLET PROTECTION DETAIL

NOT TO SCALE

1. VOLUME OF SEDIMENT STORAGE SHALL BE 3600 CUBIC FEET PER ACRE OF CONTIGUOUS DRAINAGE AREA.
- MINIMUM CREST WIDTH SHALL BE 4 X DRAINAGE AREA.
- SEDIMENT SHALL BE REMOVED AND TRAP RESTORED TO ITS ORIGINAL DIMENSIONS WHEN THE SEDIMENT HAS ACCUMULATED TO 1/2 THE DESIGN CAPACITY. THE TRAP SHALL BE MAINTAINED IN A SUITABLE AREA AND STABILIZED.
- THE STRUCTURE SHALL BE INSPECTED AFTER EACH RAIN AND REPAIRS MADE AS NEEDED.
- CONSTRUCTION OPERATIONS SHALL BE CARRIED OUT IN SUCH A MANNER THAT EROSION AND SEDIMENT ARE CONTROLLED.
- THE SEDIMENT TRAP SHALL BE REMOVED AND AREA STABILIZED WHEN THE REMAINING DRAINAGE AREA HAS BEEN PROPERLY STABILIZED.
- ALL CUT SLOPES SHALL BE 1:1 OR FLATTER.

MAXIMUM DRAINAGE AREA: 5 ACRES

ADAPTED FROM DETAILS PROVIDED BY USDA - NRCS, NEW YORK STATE DEPARTMENT OF ENVIRONMENTAL CONSERVATION, NEW YORK STATE SOIL & WATER CONSERVATION COMMITTEE

STONE & BLOCK DROP INLET PROTECTION DETAIL

August 2009
 Page 5A.40
 New York Standards and Specifications
 For Trenches and Sediment Control

August 2009
 Page 5A.40
 New York Standards and Specifications
 For Trenches and Sediment Control

STOP BAR PAVEMENT MARKING DETAIL

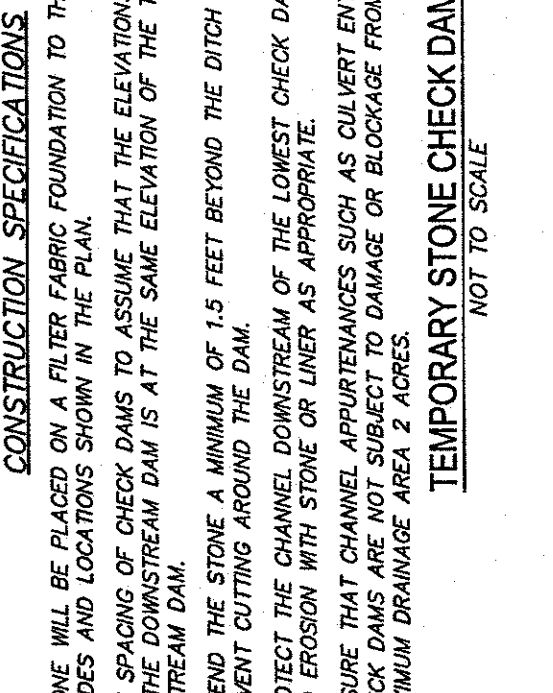

- CONSTRUCTION SPECIFICATIONS**
- STONE SIZE - USE 2" STONE, OR RECLAIMED OR RECYCLED CONCRETE EQUIVALENT.
 - LENGTH - AS REQUIRED, BUT NOT LESS THAN 30 FEET.
 - THICKNESS - NOT LESS THAN SIX (6) INCHES.
 - CONSTRUCTION SHALL BE IN ACCORDANCE WITH NYSDOT STANDARD SPECIFICATIONS SECTION 240 AND 241.
 - FLYER CLOTH - SHALL BE PLACED OVER THE ENTIRE AREA PRIOR TO PLACING OF STONE.
 - SURFACE WATER SHALL BE KEPT FROM THE STOP BAR. SURFACE WATER SHALL BE KEPT FROM THE STOP BAR. SURFACE WATER SHALL BE KEPT FROM THE STOP BAR.
 - WHEELS SHALL BE CLEANED WHEN NECESSARY TO REMOVE SEDIMENT FROM THE STOP BAR. WHEELS SHALL BE CLEANED WHEN NECESSARY TO REMOVE SEDIMENT FROM THE STOP BAR.
 - PERIODIC INSPECTION AND NEEDED MAINTENANCE SHALL BE PROVIDED AFTER EACH RAIN.

STABILIZED CONSTRUCTION ENTRANCE

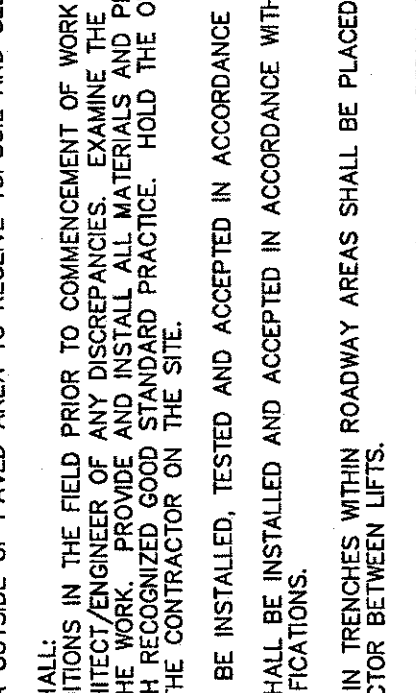

- CONSTRUCTION SPECIFICATIONS**
- STONE SIZE - USE 2" STONE, OR RECLAIMED OR RECYCLED CONCRETE EQUIVALENT.
 - LENGTH - AS REQUIRED, BUT NOT LESS THAN 30 FEET.
 - THICKNESS - NOT LESS THAN SIX (6) INCHES.
 - CONSTRUCTION SHALL BE IN ACCORDANCE WITH NYSDOT STANDARD SPECIFICATIONS SECTION 240 AND 241.
 - FLYER CLOTH - SHALL BE PLACED OVER THE ENTIRE AREA PRIOR TO PLACING OF STONE.
 - SURFACE WATER SHALL BE KEPT FROM THE STOP BAR. SURFACE WATER SHALL BE KEPT FROM THE STOP BAR. SURFACE WATER SHALL BE KEPT FROM THE STOP BAR.
 - WHEELS SHALL BE CLEANED WHEN NECESSARY TO REMOVE SEDIMENT FROM THE STOP BAR. WHEELS SHALL BE CLEANED WHEN NECESSARY TO REMOVE SEDIMENT FROM THE STOP BAR.
 - PERIODIC INSPECTION AND NEEDED MAINTENANCE SHALL BE PROVIDED AFTER EACH RAIN.

STOP BAR PAVEMENT MARKING DETAIL



- CONSTRUCTION SPECIFICATIONS**
- STONE SIZE - USE 2" STONE, OR RECLAIMED OR RECYCLED CONCRETE EQUIVALENT.
 - LENGTH - AS REQUIRED, BUT NOT LESS THAN 30 FEET.
 - THICKNESS - NOT LESS THAN SIX (6) INCHES.
 - CONSTRUCTION SHALL BE IN ACCORDANCE WITH NYSDOT STANDARD SPECIFICATIONS SECTION 240 AND 241.
 - FLYER CLOTH - SHALL BE PLACED OVER THE ENTIRE AREA PRIOR TO PLACING OF STONE.
 - SURFACE WATER SHALL BE KEPT FROM THE STOP BAR. SURFACE WATER SHALL BE KEPT FROM THE STOP BAR. SURFACE WATER SHALL BE KEPT FROM THE STOP BAR.
 - WHEELS SHALL BE CLEANED WHEN NECESSARY TO REMOVE SEDIMENT FROM THE STOP BAR. WHEELS SHALL BE CLEANED WHEN NECESSARY TO REMOVE SEDIMENT FROM THE STOP BAR.
 - PERIODIC INSPECTION AND NEEDED MAINTENANCE SHALL BE PROVIDED AFTER EACH RAIN.

STABILIZED CONSTRUCTION ENTRANCE



- CONSTRUCTION SPECIFICATIONS**
- STONE SIZE - USE 2" STONE, OR RECLAIMED OR RECYCLED CONCRETE EQUIVALENT.
 - LENGTH - AS REQUIRED, BUT NOT LESS THAN 30 FEET.
 - THICKNESS - NOT LESS THAN SIX (6) INCHES.
 - CONSTRUCTION SHALL BE IN ACCORDANCE WITH NYSDOT STANDARD SPECIFICATIONS SECTION 240 AND 241.
 - FLYER CLOTH - SHALL BE PLACED OVER THE ENTIRE AREA PRIOR TO PLACING OF STONE.
 - SURFACE WATER SHALL BE KEPT FROM THE STOP BAR. SURFACE WATER SHALL BE KEPT FROM THE STOP BAR. SURFACE WATER SHALL BE KEPT FROM THE STOP BAR.
 - WHEELS SHALL BE CLEANED WHEN NECESSARY TO REMOVE SEDIMENT FROM THE STOP BAR. WHEELS SHALL BE CLEANED WHEN NECESSARY TO REMOVE SEDIMENT FROM THE STOP BAR.
 - PERIODIC INSPECTION AND NEEDED MAINTENANCE SHALL BE PROVIDED AFTER EACH RAIN.